



# Electric Engine Room Crane

www.chinaWinches.cn

For the Single Beam Engine Room Crane and Double Beam Engine Room Crane



*Double Beam Engine Room Crane:*

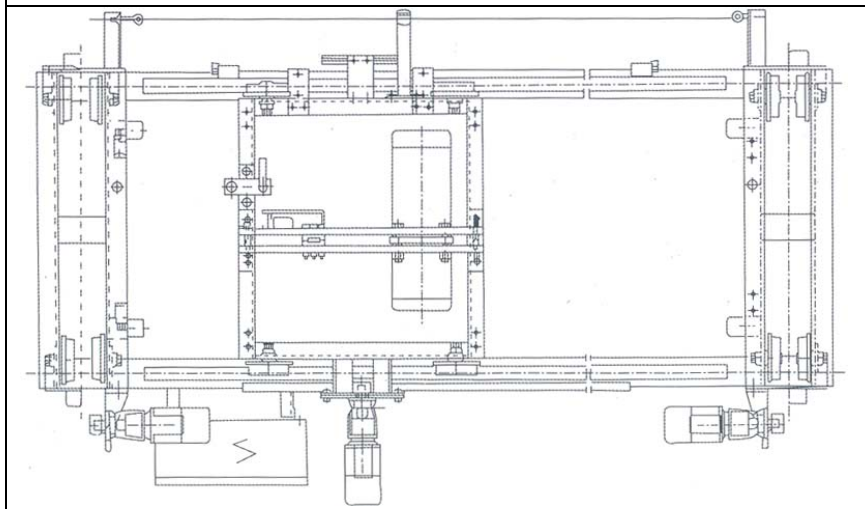
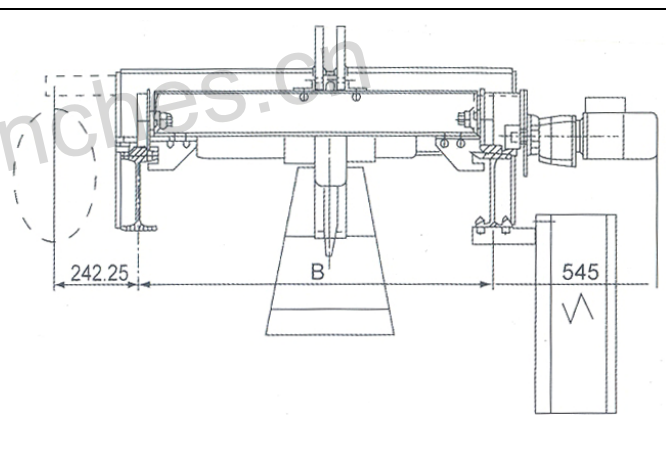
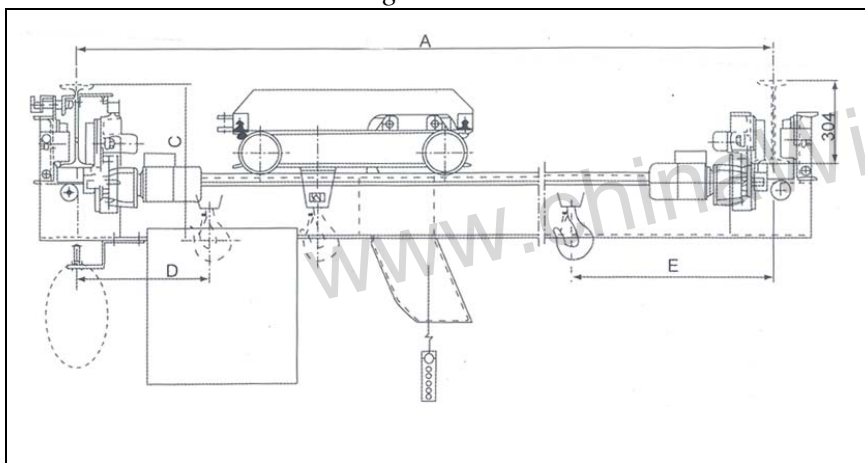

Technical data information:

Type	SWL (Ton)	Speed (M/min)		Span (M)	Weight (KG)
		Hoist	Travel		
DBE2	2	2.5/0.6	6.5	4	800
				5	900
				6	1050
				7	1250
DBE3	3	3.6/0.8	6.5	4	1000
				5	1100
				6	1300
				7	1500
DBE5	5	3.6/0.8	6.5	4	1300
				5	1500
				6	1700
				7	2000

Note: motor supply normally AC380V, 50HZ. And heel/ trim angle is 5°/ 2°



Single Beam Engine Room Crane:

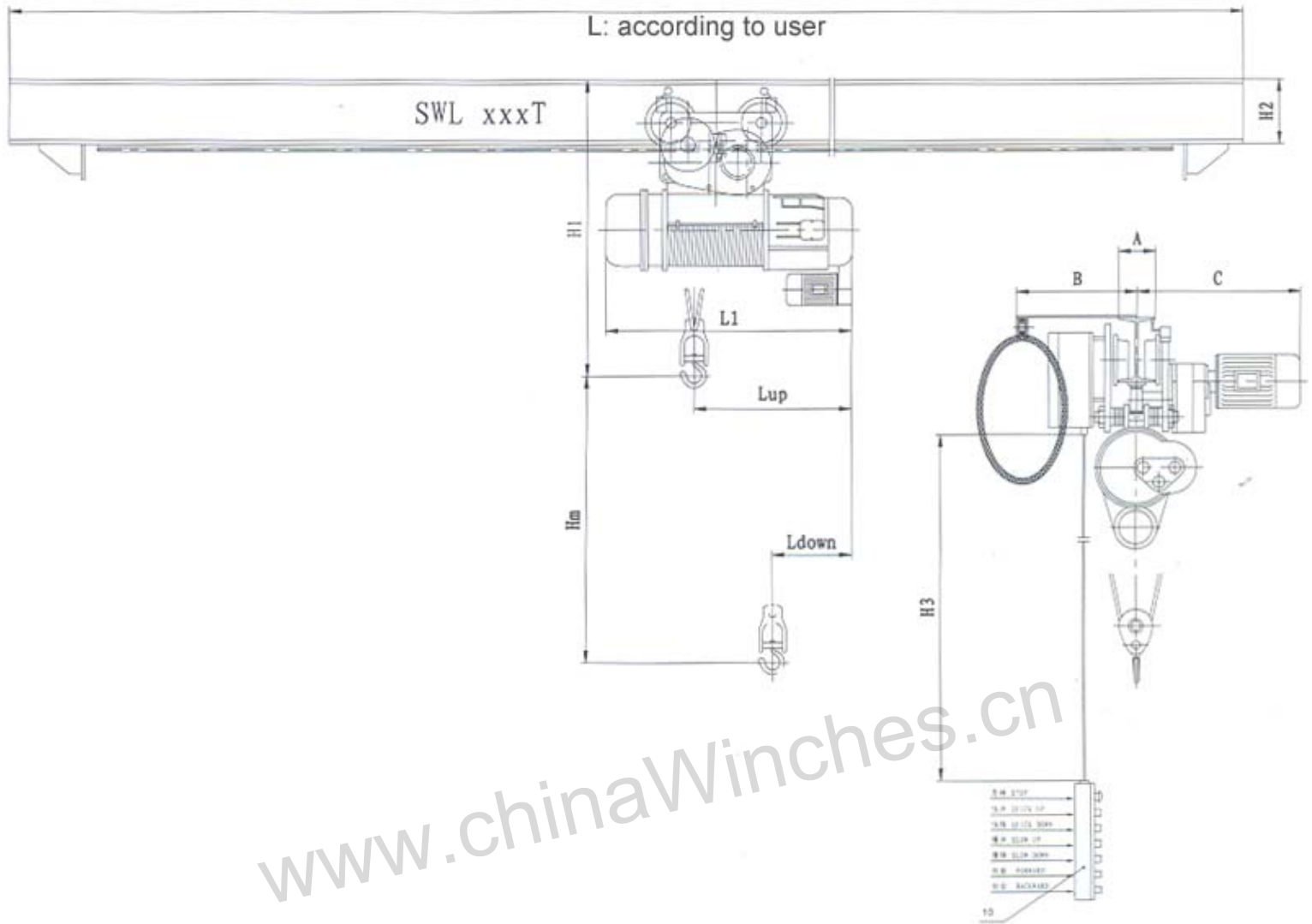

Technical data information:

Model	SBE 0.5T	SBE 1.0T	SBE 2.0T	SBE 3.0T	SBE 5.0T	SBE 10.0T	Above 10 Ton
SWL (Ton)	0.5	1.0	2.0	3.0	5.0	10.0	Design according to user.
Hoisting height (M)	6-8	6-30	6-30	6-30	6-30	6-30	
Hoist speed (M/min)	0-8	0-8	0-8	0-8	0-8	0-7	
Running speed (M/min)	0-6						
Motor power (KW)	0.8/0.2	1.5/0.4	3.0/0.4	4.5/0.8	7.5/0.8	13/1.5	
Bend radius (Rmin)	=1M	=1.2M	=1.5M	=2.5M	=2.5M	=3.0M	
Running length (M)	According to user						
Motor supply	AC380V, 50HZ / AC440, 60HZ / AC400V, 50HZ						

Note: motor supply normally AC380V, 50HZ. And heel/ trim angle is 5°/ 2°

Figure demission:

	Hm	H1	H2	H3	L1	L up	L down	A	B	C
0.5T	6-18M	820/910	180	6-18M	690-920	410-570	350	94	400	450
1.0T	6-30M	970/1070	200	6-30M	775-1555	485-910	385	102	400	450
2.0T	6-30M	1260/1360	220	6-30M	820-1620	500-925	400	112	450	500
3.0T	6-30M	1320/1420	280	6-30M	970-1790	600-1090	490	118	450	500
5.0T	6-30M	1660/1720	360	6-30M	1090-1910	645-1090	540	132	500	550
10.0T	6-30M	2200	560	6-30M	1420-2870	765-1290	630	178	500	600

[www.chinaWinches.cn](http://www.chinaWinches.cn)